

CONGRATULATIONS ON THE PURCHASE OF YOUR NEW CASA LUSSO TAPWARE, WE HOPE YOU AND YOUR FAMILY ENJOY YOUR NEW PRODUCT AND CONSIDER US FOR ANY FUTURE PROJECT. CASA LUSSO PRODUCTS HAVE BEEN MANUFACTURED UNDER THE HIGHEST STANDARDS OF QUALITY AND WORKMANSHIP.



Chrome
EV100-CH



Matte Black
EV100-MB



WaterMark
AS/NZS 3718
LN030023
Casa Lusso



EVOKE Basin Mixer Handle
- EV-BH-CH / MB / BB / BN



EVOKE Basin Mixer Cut Out Handle
- EVC-BH-CH / MB / BB / BN



EVOKE Basin Mixer Angled Handle
- EVA-BH-CH / MB / BB / BN



Optional Handles available in 4 finishes
Handles Sold Separately

GENERAL INFORMATION

MAINTENANCE

- Clean regularly using mild soap and dry with a soft cloth.
- Do not use abrasive cleaners, harsh detergents or citrus based cleaners on any products as these will scratch the surface.
- Tightening or adjustment of Tapware over time is considered general maintenance.
- Failure to clean/replace aerators/flow restrictors as required will void warranty.
- Damage to finishes that arise from installation or post installation will void warranty.

The warranty will not apply if:

- The product has been damaged by improper use;
- The product has not been used in accordance with any applicable instruction guide;
- The purchaser has attempted to modify or repair the product;
- The purchaser has failed to observe the cleaning and maintenance guidelines;
- The product is not installed by a licenced Plumber.
- Flow controllers/ aerators not regularly cleaned/ replaced.

Product warranties are personal to the person who acquires the product for their own consumption or use and not for resale or resupply. Claims with this product cannot be made by anyone other than the consumer. Where a product is covered by parts and labour warranty, the warranty covers both the repair of the defective part or the provision of a spare part to replace the defective part and the installation of that part. Where a product is covered by parts only, the warranty covers both the repair of the defective part or the provision of a spare part in replacement. It does not include the removal of the defective part or the installations of the repaired or replaced part. We reserve the right to provide minor components (e.g. handles, aerators, hoses, dress rings and washers) as 'Parts Only' to the customer. Casa Lusso reserves the right to alter, or amend this warranty offer in writing at any time.

FEATURES

Product Code: EV100-CH / EV100-MB

Premium Warranty (Domestic Use) :

15 year Ceramic cartridge replacement only
7 year Replacement products and parts¹
1 year parts & labour²

Material: Solid Brass Construction

WELS: WELS 6 Star, 4.5 litres per minute

Made to Australian Standards code:
AS/NZS 3718
Water supply - Tapware LN030023

¹ Excludes Damage to ceramic disk cartridges from pieces of copper tube, plastic tube, sand, dirt or thread tube etc. All speciality finishes are subject to 2 year replacement product and parts and 1 year replacement product and parts & labour. ² Jumper valves and ceramic disk spindles; 1 year parts only.

FAILURE TO COMPLY WITH ANY OF THE ABOVE INSTRUCTIONS WILL VOID ALL WARRANTIES

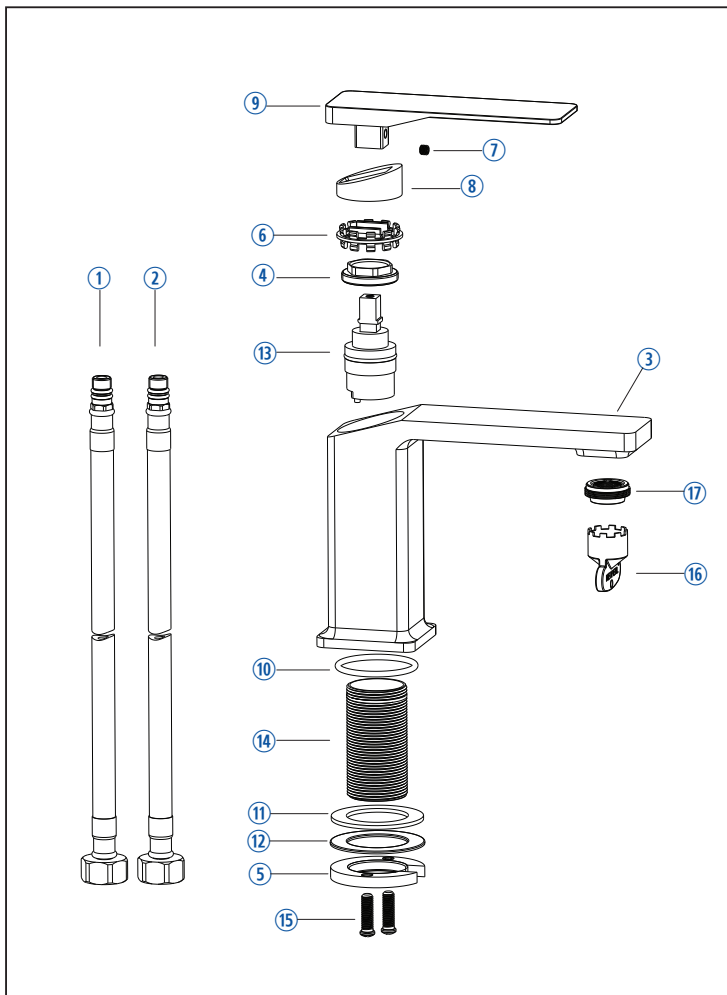

CONTENTS

① Flexible Hose (Blue)	⑩ O-ring
② Flexible Hose (Red)	⑪ Gasket
③ Body	⑫ Gasket
④ Retaining Nut	⑬ Cartridge
⑤ Horse Shoe	⑭ Thread
⑥ Ring	⑮ Screw x 2
⑦ Screw	⑯ Aerator Key
⑧ Decoration Cap	⑰ Aerator
⑨ Handle	

IMPORTANT

IT IS IMPORTANT TO FLUSH OUT THE WATER PIPES BEFORE INSTALLING THE MIXER.

- Hot and cold water inlet pressures should be equal.
- Inlet pressure range: 150 – 500 kPa
- New Regulation:
500 kPa maximum operating pressure at any outlet within a building. (Ref. AS/NZS 3500)
- Maximum hot water temperature: 80°C.

INSTALLATION

1. Install the flexible hoses into the mixer and hand tighten in place. The flexible hoses are to be fitted into the correct inlets for hot water and for cold water (Red band for hot and blue band for cold). Ensure hoses are not twisted, kinked or bent.

DO NOT USE SPANNER TO TIGHTEN AS IT CAN DAMAGE THE O RING

2. Place the mixer into position and secure by tightening the Horse Shoe and Screws.

IT IS IMPORTANT TO FLUSH OUT THE WATER PIPES BEFORE INSTALLING THE MIXER.

3. Ensure gauze strainers are placed into the flexible hoses then connect to the isolating taps.

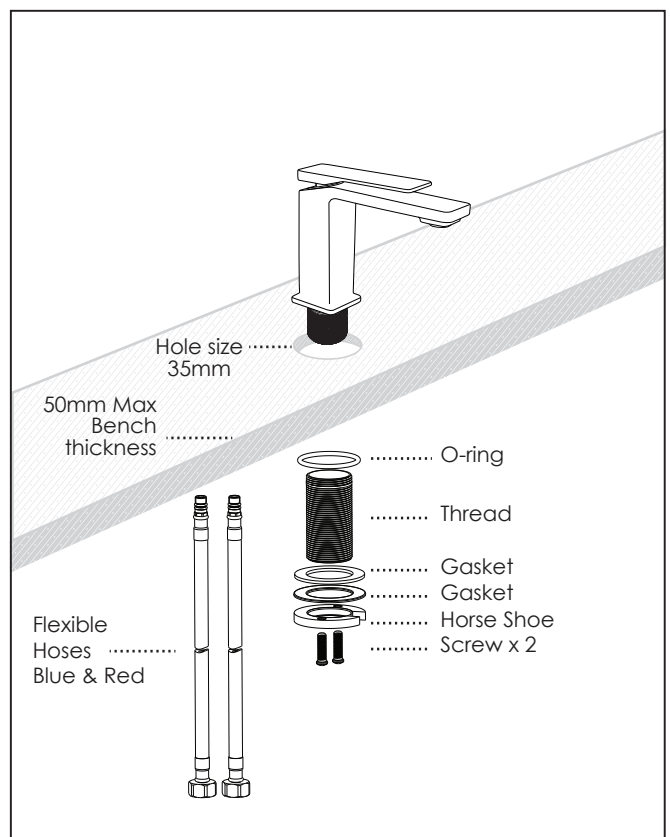

FAILURE TO COMPLY WITH ANY OF THE ABOVE INSTRUCTIONS WILL VOID ALL WARRANTIES